



Onyx™ Sliding Patio Door Lock



ASSA ABLOY

ASSA ABLOY, the global leader
in door opening solutions

Contents

| | |
|------------------------------------|----------|
| Features and Specifications | 1 |
| Handle Options | 3 |
| Strike Options | 4 |
| Ordering Procedure | 5 |

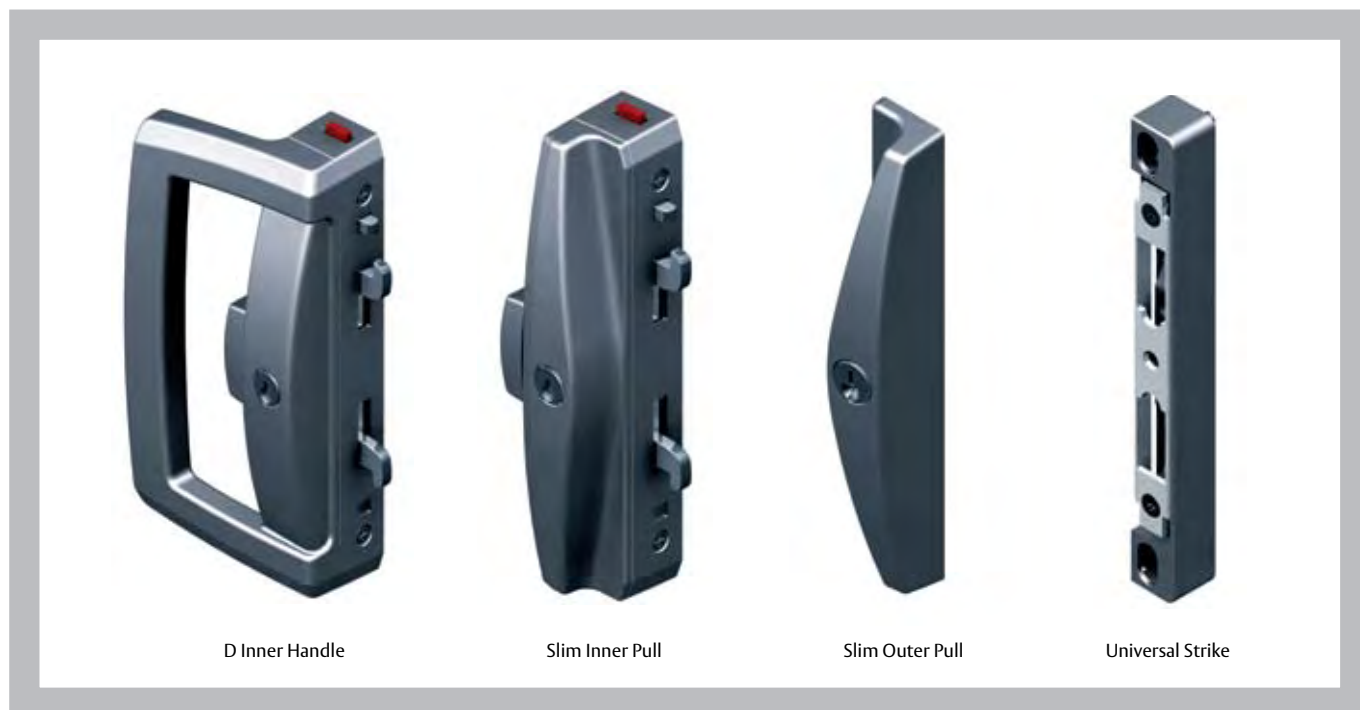

D Inner Handle

Slim Inner Pull

Slim Outer Pull

Universal Strike

The Lockwood Onyx range incorporates advanced security and safety features making this product the ideal choice for sliding patio door applications.

Style and Function

This range takes design cues from contemporary architectural styling and complements several of Lockwood's most popular levers to provide a harmonious look and feel throughout the home.

The functionality of the Onyx range has been enhanced by the intuitive operation of the unique sliding snib and the innovative LockAlert feature that indicates the lock status at a glance.

Application

Surface mounted lockset suitable for use with most aluminium and timber sliding doors.

The flexible chassis coupled with innovative design features results in a non handed product that is extremely easy to install and suitable for new and most retrofit applications.

General Features

- Twin locking beaks for added security
- Door Close Detect button (DCD) anti slam feature protects locking beaks from accidental damage
- **LOCKALERT** indicator shows lockset status at a glance
- **DUALSELECT** enables two stage key locking
- **SAFETYRELEASE** function minimises the risk of being locked in
- Ergonomic sliding snib with intuitive downward motion to unlock

Strength and Durability

Made to the highest quality levels, the Onyx range satisfies the Australian Standard requirements for strength and durability.

Product Range

A wide selection of furniture options are available in the Onyx range to suit various sliding door applications. The range includes Internal D handles and slim pulls, and a variety of external furniture and strike options.



Onyx™ Sliding Patio Door Lock

Door Thickness

Door thickness range 19mm to 50mm with the standard screw fixing pack provided.

Longer screws and tailbars are available upon application.

Fixing

Surface mounted lockset with concealed fixing. Industry standard 82mm pitching centres.

Handing

Field selectable handing enables installer to easily select the handing during installation.

Keying

- 5 pin cylinder as standard
- 6 pin cylinder is available as special order
- All key barrels come in satin chrome finish

Materials

- Zinc diecast construction
- Brass cylinders

Standards

Conforms to Australian Standard, Locksets: Mechanical locksets for doors in buildings AS4145.2-1993.

- Security – S1
- Durability – D3

Standard Finishes

- Black powder coat – BLK
- Silver powder coat – SIL
- White powder coat – WH
- Satin Chrome Pearl plated – SCP

Other plated and powder coated finishes available as special order.



Onyx™ Sliding Patio Door Lock

D Inner Handle



Dimensions

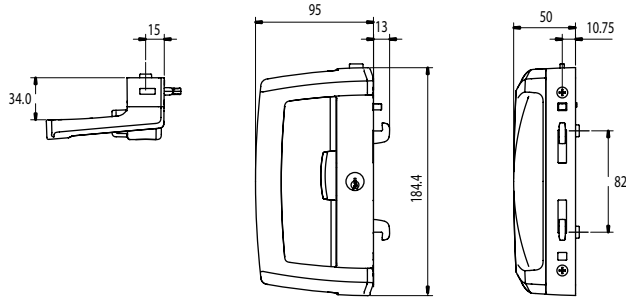

Slim Inner Pull

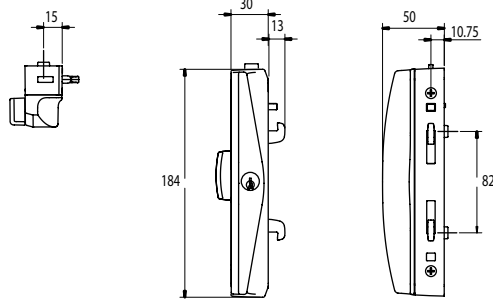

Slim Outer Pull

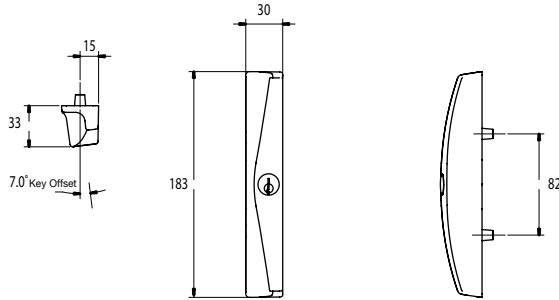

Flat Outer Pull

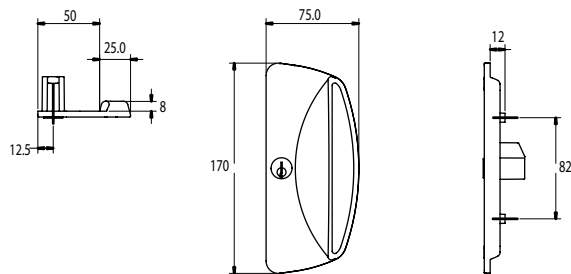

Mortice Outer Pull

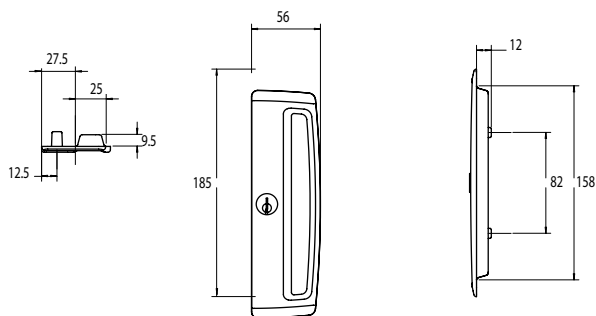

Cover Plate

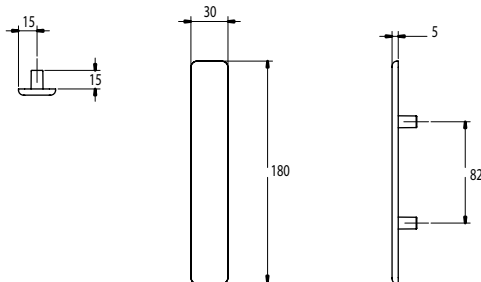

Onyx™ Sliding Patio Door Lock

Universal Strike



Dimensions

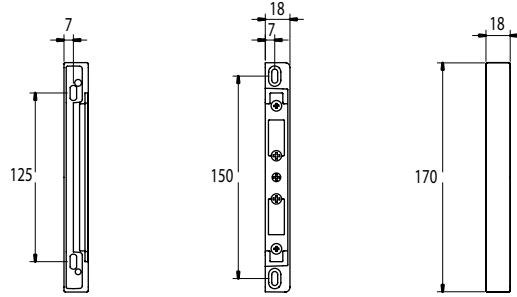

Extra Width Strike

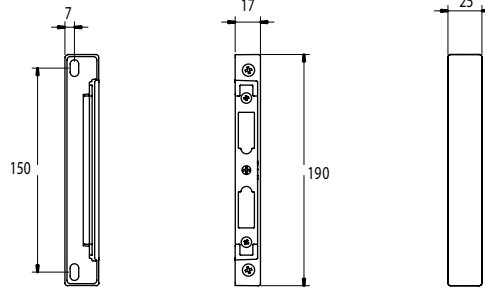

Side Fix Strike

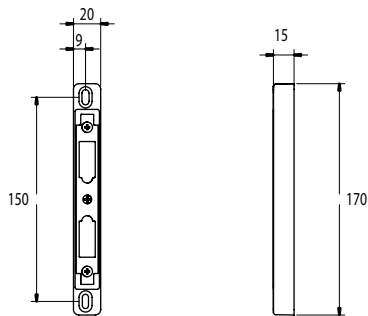

Surface Fix Strike

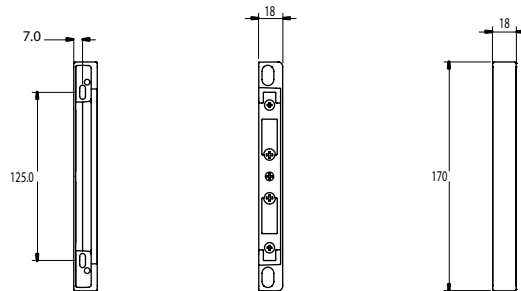

15mm Surface Fix Strike

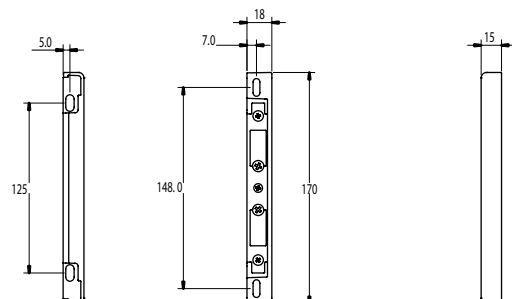

Configuration Matrix [For Reference Only]

Sample Part Number 9A1B1/5PBLK is made up of several sections. Choose your product by selecting an option from each section.

For example:

| | | | | | |
|------------------|--------------------|--------------------|--------|----------|--------|
| Platform / Suite | Internal Furniture | External Furniture | Strike | Cylinder | Colour |
| 9A | 1 | B | 1 | 5P | BLK |

| Platform / Suite | |
|------------------------------|----|
| Lockwood Patio Door, Style A | 9A |

| Internal Furniture | |
|--|---|
| No internal furniture * | 0 |
| D handle locking | 1 |
| D handle non locking | 2 |
| Slim pull locking | 3 |
| Slim pull non locking | 4 |
| D handle Dummy | 5 |
| Slim handle Dummy | 6 |
| DAS handle locking (D with aided snib) | 7 |
| DAS handle non locking (D with aided snib) | 8 |

| External Furniture | |
|-----------------------------|---|
| No external furniture * | X |
| Slim pull locking | A |
| Slim pull non locking | B |
| Flat outer pull locking | C |
| Flat outer pull non locking | D |
| Mortice pull locking | E |
| Mortice pull non locking | F |
| Cover Plate | G |
| D handle locking | H |
| D handle non locking | I |

* Exterior furniture plate is required to fix internal furniture to door with through screws.

| Strike | |
|-------------------------|---|
| No Strike | 0 |
| Surface (Front) Fix | 1 |
| Universal Fix | 2 |
| Extra Width Surface Fix | 3 |
| Side (Face) Fix | 4 |
| Surface 15mm Fix | 5 |

| Cylinder | |
|---|----|
| 5 pin cylinder/s | 5P |
| 6 pin cylinder/s | 6P |
| No cylinders – order cylinder separately | NC |
| Non keyed lockset | XX |

| Colour | |
|------------------------|-----|
| Black | BLK |
| Silver | SIL |
| White | WH |
| Satin Chrome (pearl) | SC |
| Polyester Powder Coat* | PPC |

* Specify Colour (Dulux number), additional lead time and costs apply.

Furniture comes complete with lock or dummy chassis and fixing screw pack to suit 19 – 50mm thick doors.

* No internal furniture option will also come less lock chassis.

^ Part number convention is for reference only, not all possible combinations will be available as a pre packed lockset. Some configurations will need to be made up of sub-assemblies. ie. Two or more line items may be required to make up desired configuration.

Specification Service

For all Architectural hardware specification assistance refer to your local ASSA ABLOY Sales Office.

A fully comprehensive, obligation free, Architectural Door Hardware specification can be prepared by Architectural Hardware Representatives.

Cleaning

Care should be taken during construction/ refurbishment to ensure that paint, thinners, mortar or cement splashes are carefully removed from locks, furniture and hardware. Removal of these splashes with strong cleaning agents or scourers should be avoided.

Dirt and grime should be regularly removed with a soft damp cloth. A solution of mild soap and water may be required. During cleaning, care should be taken to prevent cleaning solution from entering the cylinder keyway. Surfaces should be dried and possibly lubricated.

Lubrication

During assembly of the furniture, the areas of contact of the internal mechanism which require lubrication are given an application of high quality grease. Where an installation is exposed to temperature extremes, a dusty or dirty environment, or such that the original lubricant becomes contaminated resulting in unsatisfactory operation, then the mechanism should be cleaned with a non-corrosive solvent and re-lubricated.

Quality Endorsed Company



Australian and International Standards for Supplier's Quality Systems. Following assessment by SAI GLOBAL, ASSA ABLOY Australia Pty Limited, 235 Huntingdale Rd, Oakleigh VIC 3166 have been granted a certificate of registration as an approved supplier in the Supplier's Assessment Scheme to AS 3902/ISO 9001 – Quality Systems for Production and Installation.

Disclaimer

Whilst every effort has been made to ensure that the information contained in this catalogue is accurate at the time of publication, ASSA ABLOY recommends that you consult ASSA ABLOY or its agents prior to placing an order to ascertain current information on specific products, as ASSA ABLOY reserves the right to make changes without notice. ASSA ABLOY will not be liable for any injury, loss or damage whatsoever, arising from any errors or omissions in the information contained in the catalogue or arising from the use or application of the information contained herein. This catalogue does not constitute an offer for the sale of any particular product.



ASSA ABLOY is the global leader in door opening solutions, dedicated to satisfying end-user needs for security, safety and convenience.



assaabloy.com.au

ASSA ABLOY Sales Offices & Authorised Agents in Asia Pacific

Sales Offices – Australia

Victoria – Head Office

235 Huntingdale Road
Oakleigh VIC 3166
Telephone (03) 8574 3888
Facsimile (03) 8574 3788

Queensland South

Unit 1, 44 Cambridge Street,
Rocklea QLD 4106
Telephone (07) 3373 5200
Facsimile 1800 626 140

Queensland North

Ralph Buck Agencies
15 Mackley Street
Garbutt QLD 4814
Telephone (07) 4779 0177
Facsimile (07) 4775 1480

New South Wales – Commercial

Unit 2/16 Atkinson Road
Taren Point NSW 2229
Telephone (02) 8556 2000
Facsimile (02) 9531 7944

New South Wales – Residential

60/7-9 Percy Street
Auburn NSW 2144
Telephone (02) 9624 2666
Facsimile (02) 9620 9340

New South Wales – Abloy

5/372 Eastern Valley Way
Chatswood NSW 2067
Telephone (02) 9882 6066

South Australia

430 South Road
Marleston SA 5033
Telephone (08) 8331 6600
Facsimile (08) 8364 1975

Western Australia

37-45 Gladstone Street
Perth WA 6000
Telephone (08) 6462 8000
Facsimile (08) 6462 8025

Tasmania

23 Antill Street
South Hobart TAS 7000
Telephone (03) 6223 5404
Facsimile (03) 6224 0435

Sales Offices – New Zealand

Auckland – Head Office

6 Armstrong Road
Albany, North Shore City,
New Zealand
Telephone +64 (0)9 415 7111
Facsimile +64 (0)9 415 7222

Auckland – Commercial Sales Office

10 Haultain Street
Eden Terrace
Auckland New Zealand
Telephone +64 (0)9 622 4804
Facsimile +64 (0)9 622 4802

Christchurch

112 Wordsworth Street
Sydenham, Christchurch,
New Zealand
Telephone +64 (0)3 379 4810
Facsimile +64 (0)3 379 4819

Wellington

Level 3, 10 Hutt Road
Petone, Lower Hutt,
New Zealand
Telephone +64 (0)4 913 4214
Facsimile +64 (0)4 913 4213

Manufacturing Plants

Victoria

235 Huntingdale Road
Oakleigh VIC 3166
Telephone (03) 8574 3888
Facsimile (03) 8574 3788

New Zealand

6 Armstrong Road
Albany, North Shore City,
New Zealand
Telephone +64 (0)9 4157111
Facsimile +64 (0)9 415 7222

Security Merchants

Australia

Unit 144/45 Gilby Road
Axxess Business Park
Mount Waverley,
Victoria 3149
Telephone +61 (0)3 9558 8455
Facsimile +61 (0)3 9558 8466

New Zealand

8-10 Haultain Street
Eden Terrace, Auckland,
New Zealand
Telephone +64 (0)9 355 9240
Facsimile +64 (0)9 307 1752

Export Department

235 Huntingdale Road
Oakleigh VIC 3166 Australia
Telephone +61 (0)3 8574 3888
Facsimile +61 (0)3 8574 3789

Asian Offices

ASSA ABLOY – Malaysia
ASSA ABLOY – Singapore
ASSA ABLOY – Thailand
ASSA ABLOY – Hong Kong
ASSA ABLOY – Shanghai
ASSA ABLOY – Beijing
ASSA ABLOY – Korea
ASSA ABLOY – India
ASSA ABLOY – Japan

Contact the Export Department,
Australia for details.

Worldwide Distributors

Contact the Export Department,
Australia for details.

Lockwood Guarantee

ASSA ABLOY Australia Pty Limited ("ASSA ABLOY") warrants its Lockwood products against defects in workmanship and materials, subject to the limitations and exclusions set out in this Warranty. If, within the normal working life of a product, it is found to be defective, and none of the limitations and exclusions set out in this Guarantee apply, ASSA ABLOY will supply the same or equivalent product free of charge. This is the only remedy granted by ASSA ABLOY under this Guarantee.

Limitations

All electrical and electronic components used in ASSA ABLOY's Lockwood range of products (excluding batteries) are guaranteed for a period of 12 months from the date of proof of purchase, unless stated otherwise.

Exclusions

This Guarantee does not cover:

- Damage to or malfunction or failure of the Lockwood product caused or contributed to by:
 - improper installation or failure to follow fitting instructions;
 - improper maintenance;
 - fair wear and tear;
 - any modification or repair which has not been authorized by ASSA ABLOY;
 - use of substitute or replacement parts or cylinders other than genuine ASSA ABLOY parts or cylinders; or
 - use of batteries other than those specified by ASSA ABLOY.

- The cost of:

- removal and/or replacement of the Lockwood product;
- freight and/or travelling time;
- replacement batteries; or
- any modification or repairs to a Lockwood product, unless authorised by ASSA ABLOY.

- Damage to or deterioration of the plated finishes Florentine Bronze, Architectural Bronze, Polished Brass, Gold and Satin Brass, which are classified as soft finishes, and are subject to deterioration under some environmental conditions.

- Personal injury, property damage or economic loss, however caused.

Symmetry® 5 Year Finish Guarantee

ASSA ABLOY Australia Pty Limited will replace five-year branded Symmetry product if within five years from the proven date of purchase it tarnishes, discolours or corrodes when properly installed and subject to no more than fair wear and tear.

Symmetry® Everbrass® Guarantee

Everbrass® product is coated both on the exterior and interior surfaces with a lifetime anti-tarnish finish. ASSA ABLOY Australia Pty Limited will replace Everbrass® branded product if it corrodes, tarnishes or discolours when properly installed and subject to no more than fair wear and tear.

This Guarantee is in addition to and not in substitution for any rights of the purchaser under the Trade Practices Act and state or territory legislation.

